

PERMAFIL EDIBLE OIL FILTER

OPERATING INSTRUCTIONS

Models PF-85M & PF-110M

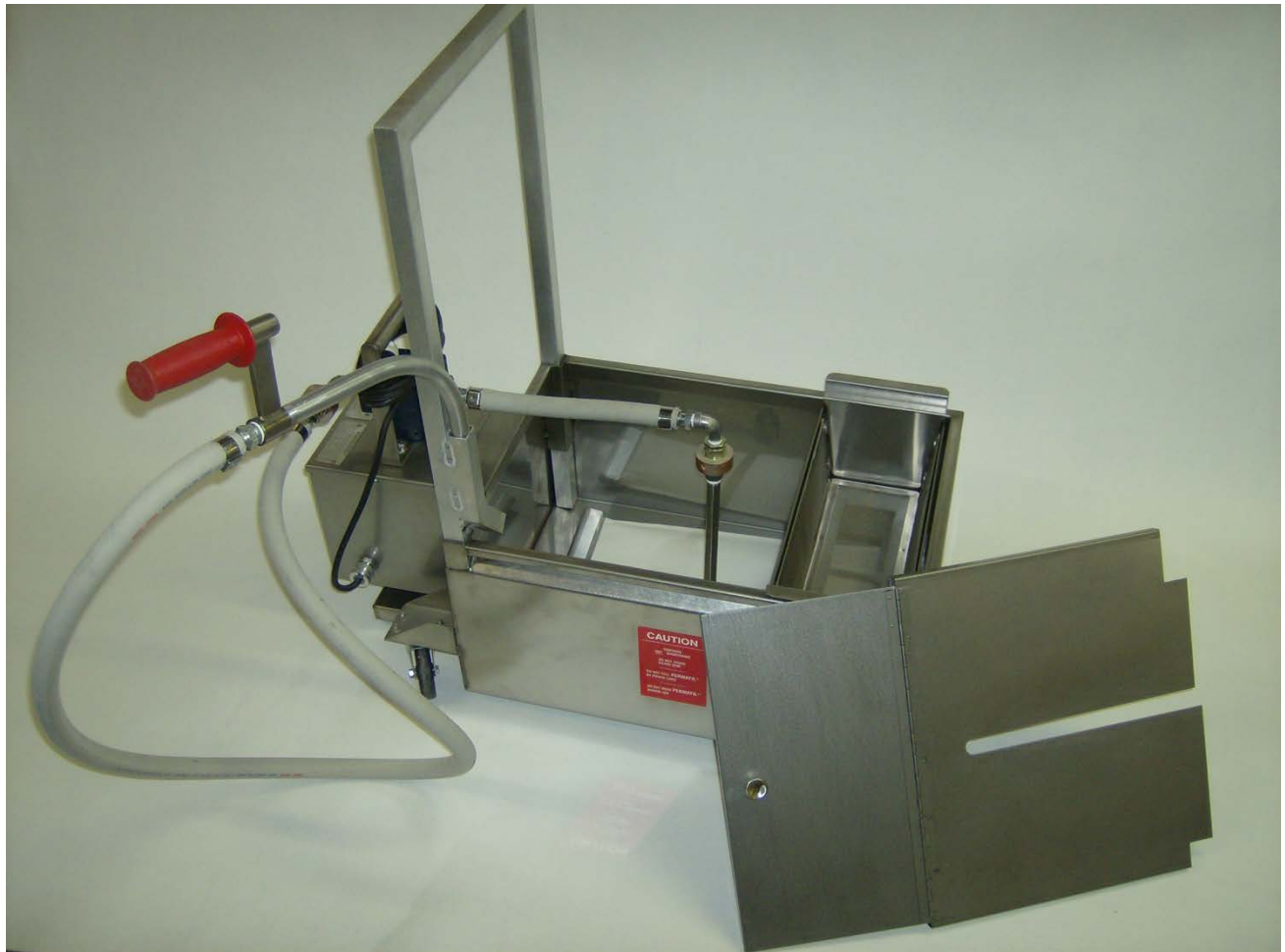

PERMAFIL FILTRATION PRODUCT DIVISION

FILTER-ALL Inc.

6907 FM 1488

MAGNOLIA, TX 77354

(281) 356-1257 * FAX (281) 356-1259

SPECIFICATION OF PERMAFIL FILTER UNITS

MODEL #	PF-85M	PF-110M
OIL CAPACITY	85 POUNDS	110 POUNDS
PUMP CAPACITY	8 GPM	8 GPM
ELECTRIC POWER	115v / 60 Hz / 1 PHASE	115v / 60 Hz / 1 PHASE
MOTOR SIZE	1/3 HP WITH OVERLOAD PROTECTOR	1/3 HP WITH OVERLOAD PROTECTOR
WEIGHT	75 POUNDS	80 POUNDS
SIZE, L x W x H	18 1/4" x 16 1/4" x 11 3/4"	23 1/2" x 16 1/4" x 11 3/4"

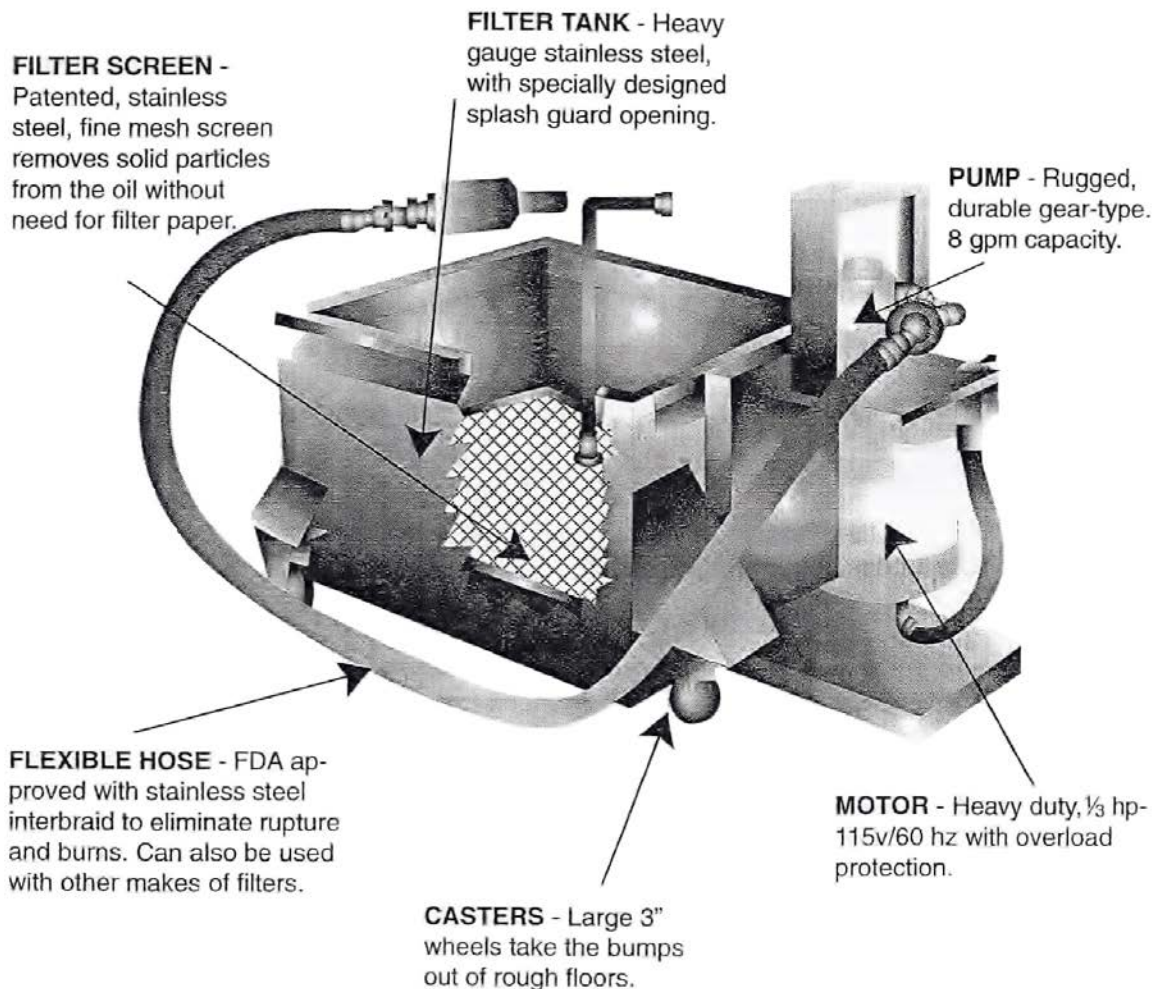

UNPACKING INSTRUCTIONS

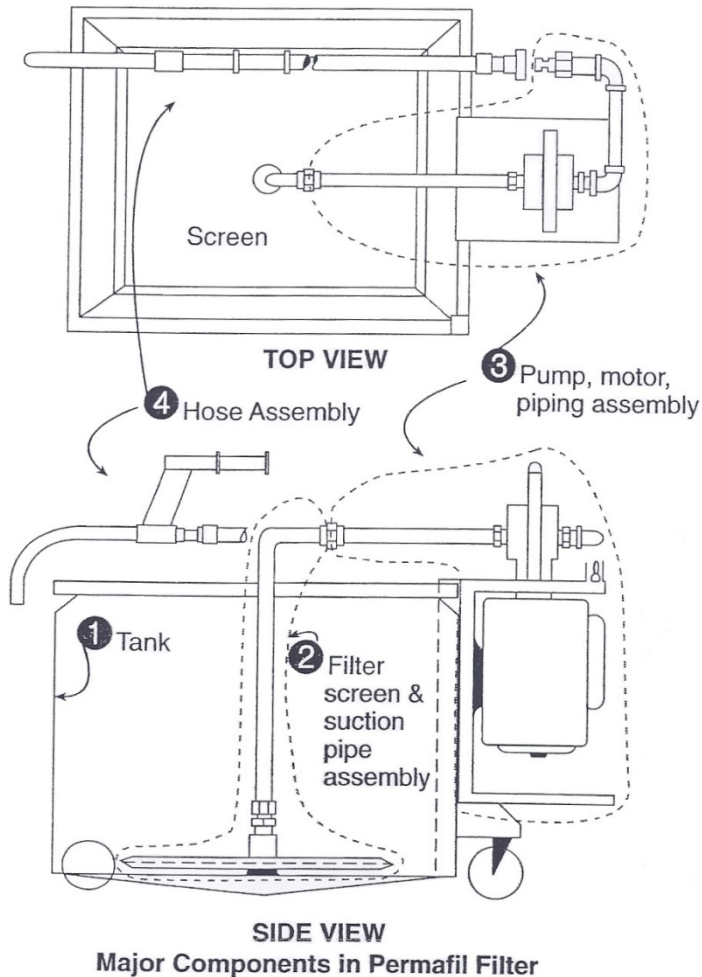

The Permafil Filter is completely assembled in its shipping carton. It may be necessary to partially disassemble it during unpacking. After reassembly, the unit is ready for use.

The filter has 4 major components:

1. Tank
2. Filter screen and suction pipe assembly
3. Pump, motor and piping assembly
4. Hose assembly

Item 3 hangs on the rear edge of item 1.

Items 2 and 4 attach to item 3 with quick connect fittings.

UNPACKING AND ASSEMBLY

1. Remove packing material and remove filter from shipping carton.
2. Remove item 3 from tank by breaking quick connect fitting from item 2. Check piping and fittings for damage in shipment. If damage is noted, contact UPS and Filter-All immediately.
3. Remove item 2 from tank. Observe screen and tank for dirt or debris, clean if necessary.
4. Replace filter in tank.
5. Hang item 3 on tank and make up fitting on screen assembly. Unit is ready for service.

ASSEMBLY INSTRUCTIONS

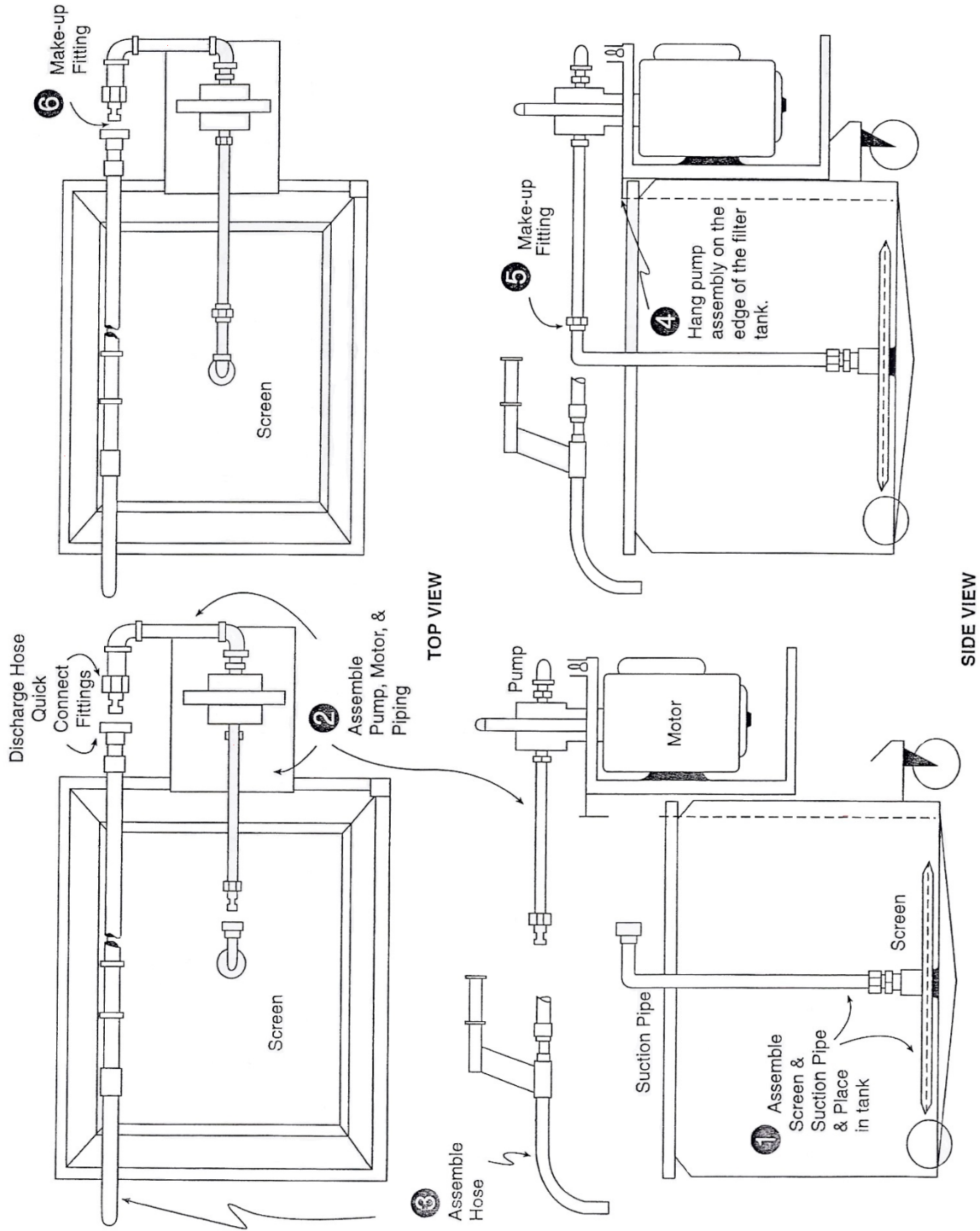

OPERATING INSTRUCTIONS

CAUTION: The equipment and cooking oil are at high temperatures. Do not touch any metal surfaces. Protective aprons, gloves and face shields should be worn at all times.

1. Position filter tank under drain valve of the fryer. Cooking oil temperature should be 325 – 350 F
2. Pour 12oz. of Permafil Filter Powder into cooking oil in the fryer and stir until it is evenly distributed.
3. Make sure the fryer is turned off.
4. Drain cooking oil into the filter tank. Use caution to avoid splashing.
5. Position hose over fryer. Turn on filter pump and wash debris from the bottom of the fryer into the filter tank. Turn pump off and insert hose nozzle into the square circulating hole in the filter tank.
6. Turn on filter pump, and circulate for 5 to 7 minutes or until the oil is clear. Turn pump off.
7. Close fryer drain valve. Position hose over the fryer.
8. Turn on filter pump and pump the oil from the filter into the fryer. Stop the pump when the oil level in the filter tank is below the top of the filter screen.
9. Proceed to the next fryer and repeat except omit step 2.
10. After oil in all the fryers have been treated, allow filter to cool, and commence cleaning procedures. See page 5.

CLEANING PROCEDURE

CAUTION: Equipment may be hot. Do not touch metal surfaces. Protective aprons, gloves and face shield should be worn.

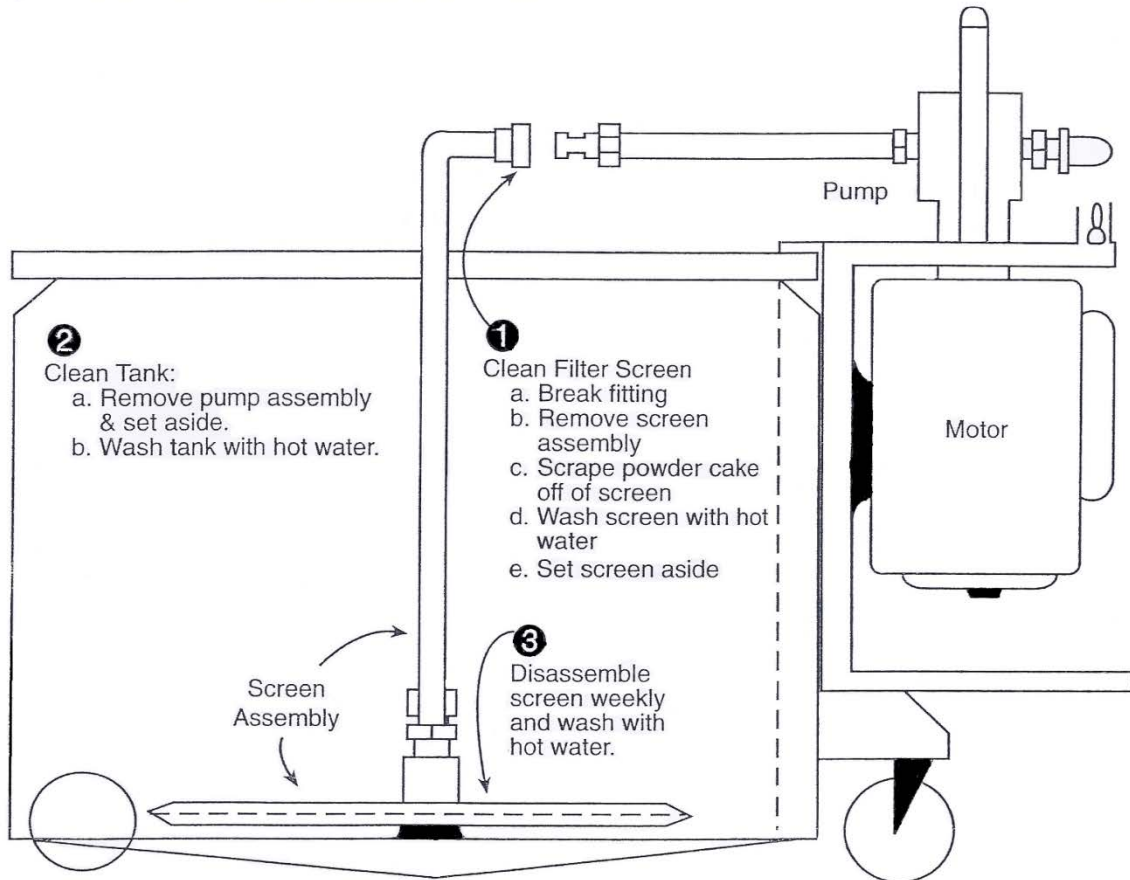

Note: If some water remains in the filter when it is put in service, it will boil out when hot cooking oil is treated. This will not hurt the oil, but may result in splattering oil. Caution must be observed.

Do not run water through pump.

MAINTENANCE SCHEDULE

1. DAILY

- a. While filter is in service, observe piping and fittings for leaks. Do not attempt to correct while the pump is running.
- b. After cooking oil treatment for the day is completed, clean filter screen and tank with hot water. See page 5 for cleaning procedures.
- c. Wipe oil from pump and motor enclosure, and other parts.

NOTE: Do not use soap. Do not run water through the pump.

2. WEEKLY

- a. Disassemble filter screen and wash with hot water.
- b. Inspect discharge hose for cracks. Cracks will appear before the hose starts to leak. However, the hose should be replaced when the cracks appear.

TROUBLESHOOTING

2 Pump won't pump

- a. Break fitting, set screen assembly aside.
- b. Start pump. Feel for vacuum on fitting. If you feel vacuum, pump is working, but screen is plugged. Clean screen. Reassemble & check for pump operation.

- c. If you feel no vacuum, replace pump.

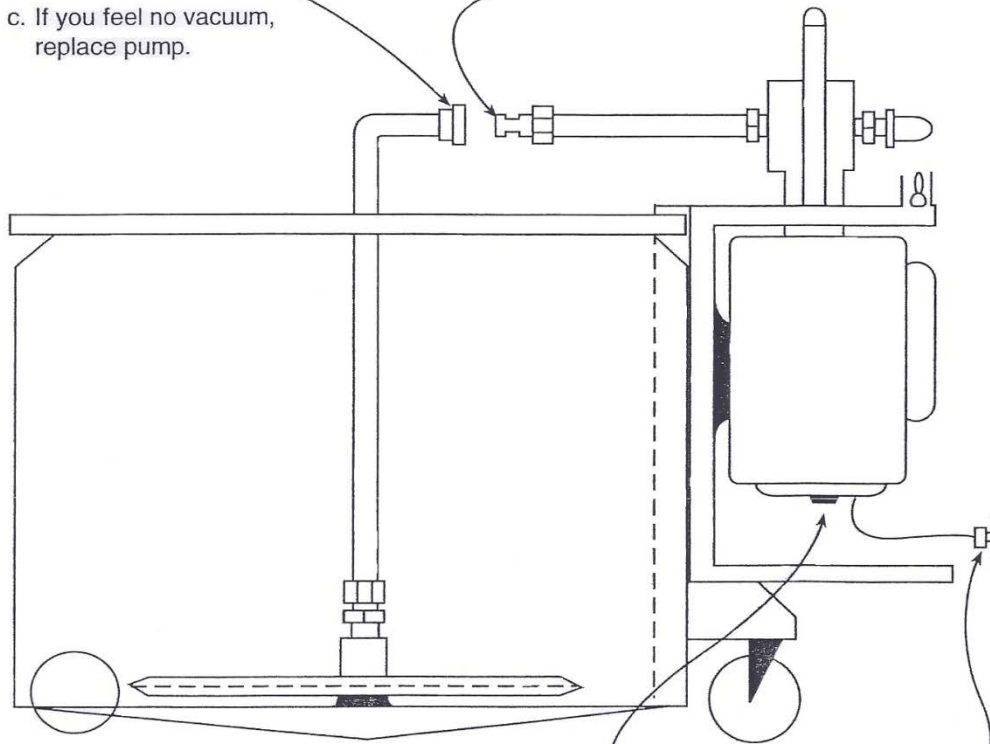

1 Motor doesn't run

- a. Check for plugged in.
- b. If motor is hot, allow to cool & push reset button.

PERMAFIL REPLACEMENT PARTS

PART #	DESCRIPTION
1A	Complete Discharge Hose Assembly (1,2,3)
1	Discharge Hose w/2 Male Fittings
2	Discharge Handle & Nozzle
3	Female Quick Disconnect Fitting
4	Male Quick Disconnect Fitting
5A	Complete Suction Assembly (4,5,6,7)
5	Suction Hose w/ 2 Male Fittings
6	Screen Pipe
7	Top Cap
8	Filter Screen
9	Insert for #8
8A	Masterfil Filter
9A	Insert for Masterfil Filter
10	Filter Tank w/ Casters, PF-85
11	Filter Tank w/ Casters, PF-110
12	Casters – Swivel (2 required)
13	Casters – Stationary (2 required)
14A	Complete Pump / Motor Assembly (4,15,16,17,18,19,20)
15	110 V AC Motor
16	8 GPM Pump
17	Stainless Steel Base Plate w/ Handle & Motor Enclosure
18	Pump Discharge Piping & Fittings
19	Pump Suction Fittings
20	Pump Switch
21	Safety Lid for PF-85
22	Safety Lid for PF-110
23	Complete Filter Unit, PF-85M
24	Complete Filter Unit, PF-110M
25	Crumb Catcher Basket

REFUNDS /RESTOCKING	TERMS
NO REFUNDS ON DAMAGED OR USED GOODS. 15% RESTOCKING CHARGE ON UNUSED MERCHANDISE. NO REFUNDS ON MERCHADISE OVER NINETY (90) DAYS	F.O.B. MAGNOLIA, TX NET 30 DAYS SUBJECT TO CREDIT APPROVAL

CALL TO ORDER
1-800-869-0976

PERMAFIL FILTER PARTS

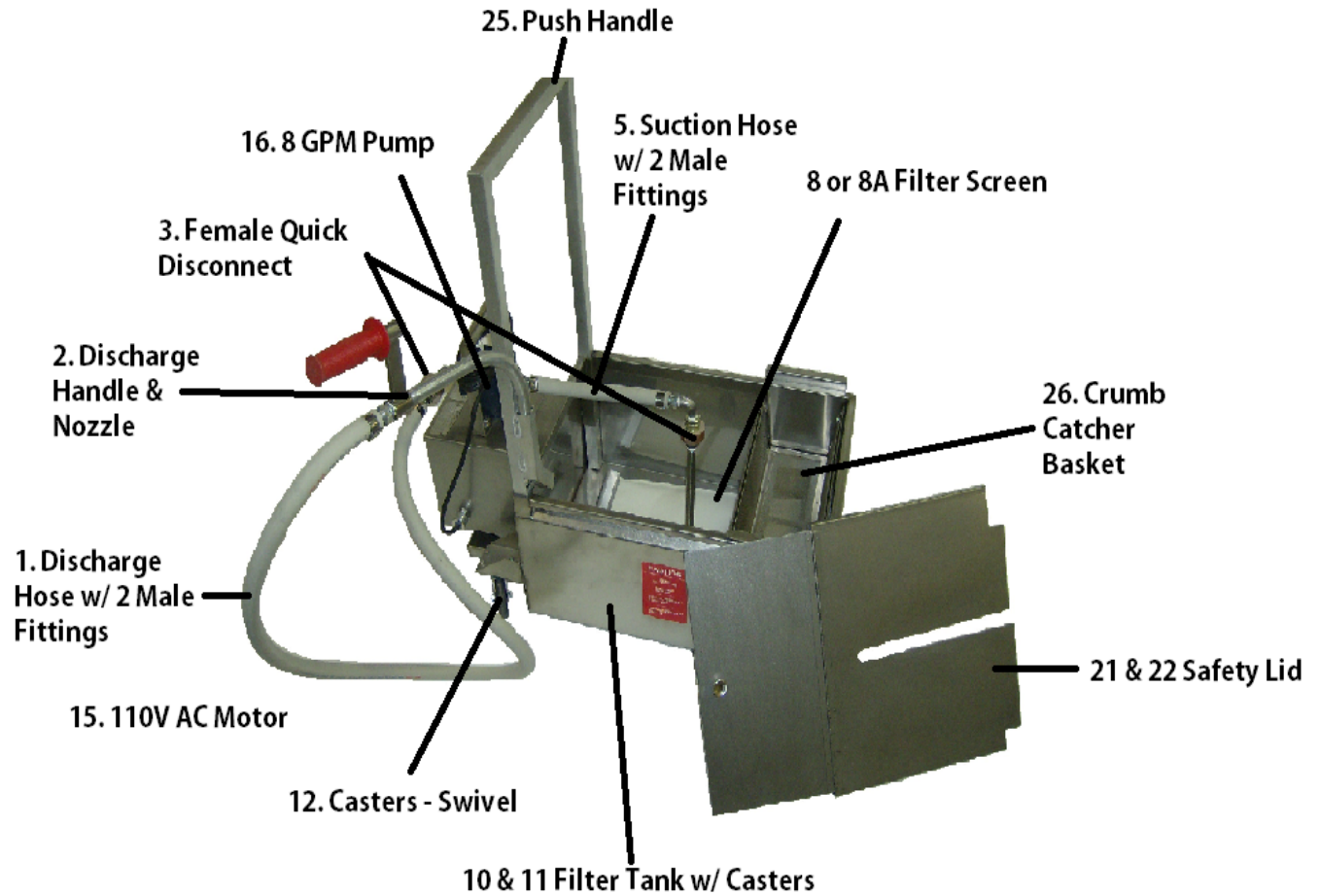

PERMAFIL LIMITED WARRANTY

This product has been manufactured and tested to the highest quality standards by Permafil, Inc. This Limited Warranty offered by Permafil, Inc. covers defects in material or workmanship in new Permafil, Inc. products. This warranty extends to the original purchaser only and is non-transferable. Only consumers purchasing Permafil, Inc. products from authorized Permafil, Inc. retailers or resellers or through the Permafil, Inc. website may obtain coverage under our limited warranties.

What is covered? Permafil, Inc. warrants this product against defects in material or workmanship as follows:

Permafil, Inc. will replace at no charge for parts only or, at its option, replace any product or part of the product that proves defective because of improper workmanship and/or material, under normal installation, use, service and maintenance. If Permafil, Inc. is unable to provide a replacement and repair is not practical or cannot be made in a timely fashion, Permafil, Inc. may elect to refund the purchase price in exchange for the return of the product.

How Long Does The Coverage Last? Our warranty periods are 6 Month from the documented date of purchase, depending on the type of product and where it was purchased.

What Our Warranty Does Not Cover? Our warranties do not cover any problem that is caused by:

- A. Conditions, malfunctions or damage not resulting from defects in material or workmanship.
- B. Conditions, malfunctions or damage resulting from (1) normal wear and tear, improper installation, improper maintenance, misuse, abuse, negligence, accident or alteration.
- C. Accessories, connected materials and products, or related products not manufactured by Permafil, Inc.

Our limited warranties are void if a product is returned with removed, damaged or tampered labels or any alterations (including removal of any component or external cover).

How to File a Claim? Permafil, Inc. will not provide any warranty coverage unless claims are made in compliance with all terms of the controlling warranty statement included with your product and you follow proper return procedure. To request warranty service, you will need to provide:

1. The sales receipt or other evidence of the date and place of purchase.
2. A description of the problem.
3. Delivery of the product or the defective part, postage prepaid and carefully packed and insured, to: Permafil Inc. 6907 FM 1488 Magnolia, TX 77354. 281-356-1258.

When warranty service is completed, any repaired or replacement product or part will be returned to you postage prepaid.

REPAIR OR REPLACEMENT (OR, IN LIMITED CIRCUMSTANCES, REFUND OF THE PURCHASE PRICE) AS PROVIDED UNDER THIS WARRANTY IS THE EXCLUSIVE REMEDY OF THE PURCHASER. PERMAFIL INC. NEITHER ASSUMES NOR AUTHORIZES ANY PERSON TO CREATE FOR IT ANY OTHER OBLIGATION OR LIABILITY IN CONNECTION WITH THIS PRODUCT.

PERMAFIL INC. SHALL NOT BE LIABLE TO PURCHASER OR ANY OTHER PERSON FOR ANY INCIDENTAL, SPECIAL OR CONSEQUENTIAL DAMAGES, ARISING OUT OF BREACH OF THIS WARRANTY OR ANY IMPLIED WARRANTY (INCLUDING BUT NOT LIMITED TO ANY IMPLIED WARRANTY OF MERCHANTABILITY).

How Does State Law Apply? The laws of the State of Texas, USA, govern our warranties. It gives you specific legal rights, and you may also have other rights that vary from state to state. Our warranties do not affect any additional rights consumers have under laws in their jurisdictions governing the sale of consumer goods. Some states do not allow the exclusion or limitation of incidental or consequential damages, so the limitations or exclusions in our warranty statements may not apply. You may be required by law to give us a reasonable opportunity to correct or cure any failure to comply before you can bring any action in court against us under the Magnuson-Moss Warranty Act.

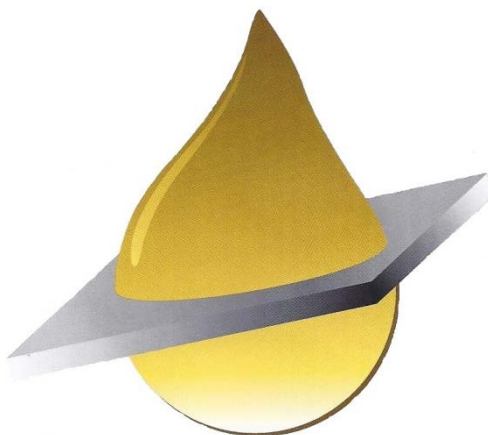

PERMAFIL FILTRATION PRODUCT DIVISION

FILTER-ALL Inc.

6907 FM 1488

MAGNOLIA, TX 77354

(281) 356-1257 * FAX (281) 356-1259

1-800-869-0976